

Brochure

WAVE PTX Tactical

Unified communications for Joint All-Domain Command and Control and Agile Combat Engagement



JITC
CERTIFIED



Any device. Any network. Complete interoperability

WAVE PTX Tactical is a mission-critical solution that extends Joint All-Domain Command and Control (JADC2) radio communications to PCs, smartphones and other devices both locally, at a forward operating location and globally wherever IP network connectivity is available. Device agnostic and interoperable with legacy systems, WAVE PTX Tactical provides powerful, new capabilities that extend your existing hardware investment for full unified communications regardless of physical or geographical barriers.

WAVE PTX Tactical is built for interoperability, enabling a single user interface for nearly all communications assets. Relying on deep interoperability with other US DoD systems and mission partners, WAVE PTX Tactical's voice interoperability gateway enables teams to use disparate communications networks and domains to communicate, plan and synchronize.

With seamless satellite IP connectivity and RF network interoperability, WAVE PTX Tactical allows you to immediately establish command and control while empowering users with voice, data and critical services minutes after arriving at any deployment area.

In addition, WAVE PTX Tactical's advanced telephony capabilities allow users to directly dial into DSN password protected channels. Now, a traditional phone user can have an instant, clear conversation with a push-to-talk (PTT) radio user. Plus, command and control operators can utilize a built-in soft phone to call anyone on the DSN. So, users can call into dispatch and be patched into any combination of resources connected to WAVE PTX Tactical.

The system can also be configured for "crash calls," where WAVE PTX Tactical calls a preconfigured list of phone numbers and brings everyone together into a single, unified conference bridge, including PC and radios users, all talking securely in real time.

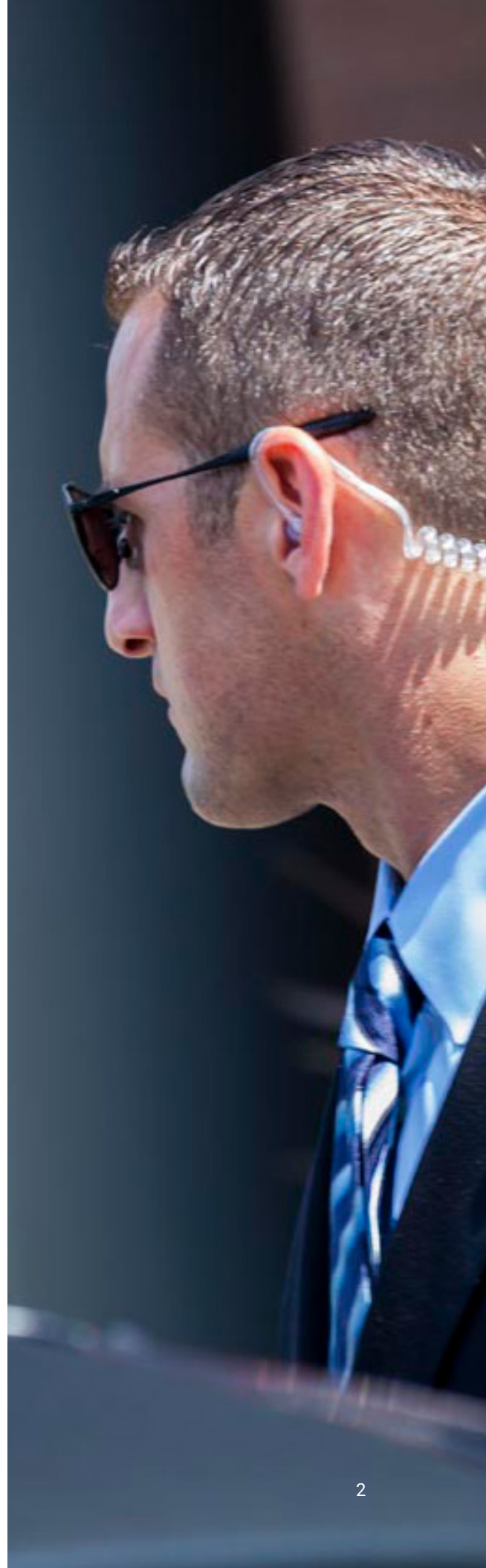



Powerful recording capabilities

WAVE PTX Tactical features powerful recording playback and archiving capabilities. It can be configured to record each individual transmission on a channel, with provided time and date. Users can add metadata to the recordings, making it easy to search and filter results.

WAVE PTX Tactical can indefinitely archive recordings or can be configured to purge data after a specified time. Using scripts, it can also offload recorded audio onto a storage area network (SAN) device or forward the audio to be used in a hardware-based recording system. The web-based UI allows for playback of all recorded audio and can be accessed from any computer connected to the WAVE PTX Tactical servers.

WAVE PTX Tactical desktop & advanced desktop communicators

WAVE PTX Tactical clients are Microsoft Windows®-based and come in two versions.

1. **Desktop Communicator:** For users who need access to voice networks.
2. **Advanced Desktop Communicator:** For users who need Command/Control roles and functions.

Both clients enable two-way simultaneous PTT access and the use of preconfigured alerts over all configured radio channels and can transmit to single or multiple channels. Plus, an “instant replay” capability allows users to instantly rewind up to 30 minutes and listen to any missed transmissions. In addition, full-time, server-side recording, offers the ability to record and archive all transmissions on every WAVE PTX Tactical channel. Both clients can also act as VoIP softphones, registering directly with an IP PBX to initiate and receive telephone calls on DSN. In addition, the Advanced Desktop Communicator has the ability to combine two or more disparate radio nets and have them appear to the users as a single, unified net.





Certified to meet your requirements

WAVE PTX Tactical is a software solution designed to allow seamless interoperability between disparate networks and devices. It interoperates between a range of devices including: tactical radios, air-to-air, air-to-ground, SATCOM, land mobile radios (LMR), PC's and laptops, smartphones, traditional cellular phones, analog and VoIP phones, paging equipment and broadcast systems such as Giant Voice.

Running completely on COTS/GOTS, WAVE PTX Tactical does not require any proprietary hardware, maximizing budget and resources. Using FIPS 140-2 compliant software and AES-256 encryption, WAVE PTX Tactical creates a flexible and secure way to interoperate.

WAVE PTX Tactical is also Joint Interoperability Test Command (JITC) certified, which allows the solution to be effortlessly deployed on the Defense Information System Network (DISN – NIPR or SIPR) and connected to the Defense Switched Network (DSN).

WAVE PTX Tactical has received numerous Certificates of Networkiness (CON)'s and Authorities to Operate (ATO)'s on various defense networks and continues to be the premier choice for defense agencies across the globe.



Expanding JADC2 and ACE in a secure mobile environment

To succeed in today's asymmetrical mission environments, government executives, command leadership, military personnel and members of the law enforcement and intelligence community all must be able to access and share information with mission partners across the globe. As a result, encrypted voice and data communications in the field are crucial to enabling tactical access to timely information and making more informed decisions in critical moments.

Motorola Solutions' Secure Mobile Environment (SME) is designed specifically to CSfC standards and holds NIAP Common Criteria certification, allowing federal personnel to access classified voice and data from anywhere, at any time, using the LEX L11 smart device.

The LEX L11 architecture allows for a unique method of providing multiple operational modes on the device. Each mode has its own authentication, data, policies and apps. Multiple security levels may safely run on a single device and even an operating system, baseband, or processor-level exploit cannot cross the boundary between modes. Additionally, LEX L11:

- Has the unique ability to be provisioned over-the-air in a disconnected state.
- Meets the latest National Security Agency / Central Security Service Data-at-Rest Capabilities Package for mobile devices.
- Is architecture agnostic, able to fit within any infrastructure in place across the federal world today.
- Has a production line in North America in a TAA Compliant Facility.



LEX L11

A purpose-built device for your agency's most challenging operations

LEX L11 is a rugged, MIL-STD 810G and IP67 certified, LTE-based smart device built to military drop and shock standards. It ensures teams receive the right information at the right time while bringing more actionable, real time intelligence directly into the hands of field personnel. It pairs the best-in-class voice and audio capabilities of our mission critical radios with smart device functionality so you can use modern applications, send and receive multimedia and instantly connect with dedicated push-to-talk functionality.

LEX L11 Features:

- Intuitive controls for head up, hands free operation
- Best-in-class audio quality and performance
- WAVE PTX Tactical with a dedicated PTT button
- End-to-end mobile security that fits seamlessly into a zero trust architecture
- Rugged construction, purpose-built to outperform even in the harshest environments
- Remote management and control with device management wall
- Standard and High-Capacity Removable Battery options

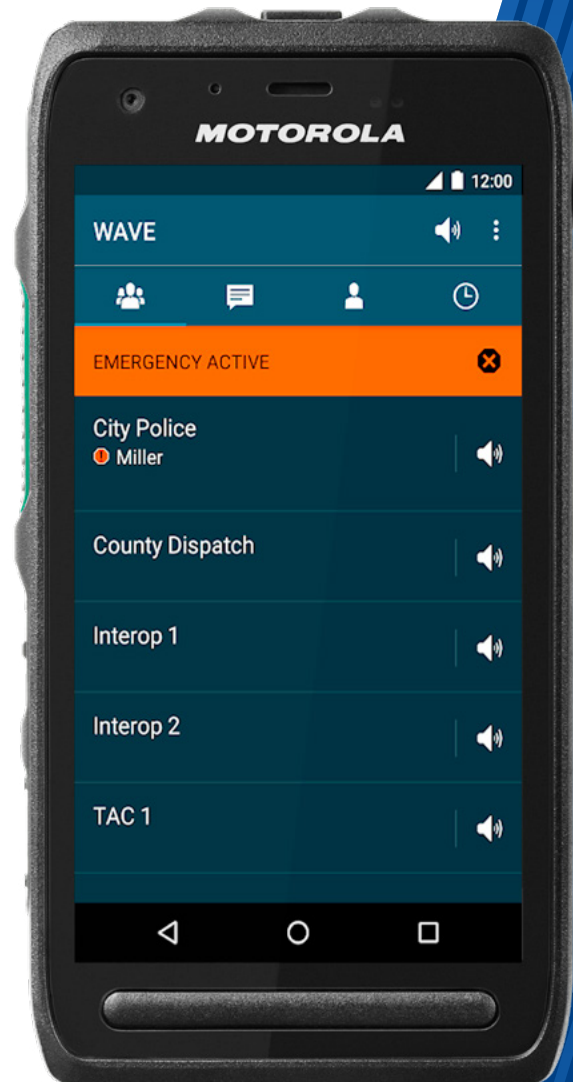

LEX L11 Mission
Critical LTE handheld



Deploying WAVE PTX Tactical

Once SATCOM or backhaul links have been established to the Mission Headquarters and/or Joint Task Force Headquarters, WAVE PTX Tactical can extend RF communication from the deployed WAVE PTX Tactical site over the backhaul to PCs and smart devices used by other command and control personnel at HQ.

WAVE PTX Tactical servers extend, or supernode, multiple audio streams over backhaul for secure, reliable and bandwidth-efficient transmission. WAVE PTX Tactical media

servers multiplex audio streams for efficient delivery over the backhaul to other WAVE PTX Tactical media servers, which then demultiplex and deliver it to all interested parties using IP multicast.

Media Servers permanently installed at the Mission Headquarters and/or Joint Task Force Headquarters receive connections from deployed WAVE PTX Tactical sites as backhaul links are established and come online.

Deployed area of operation – SATCOM backhaul to HQ

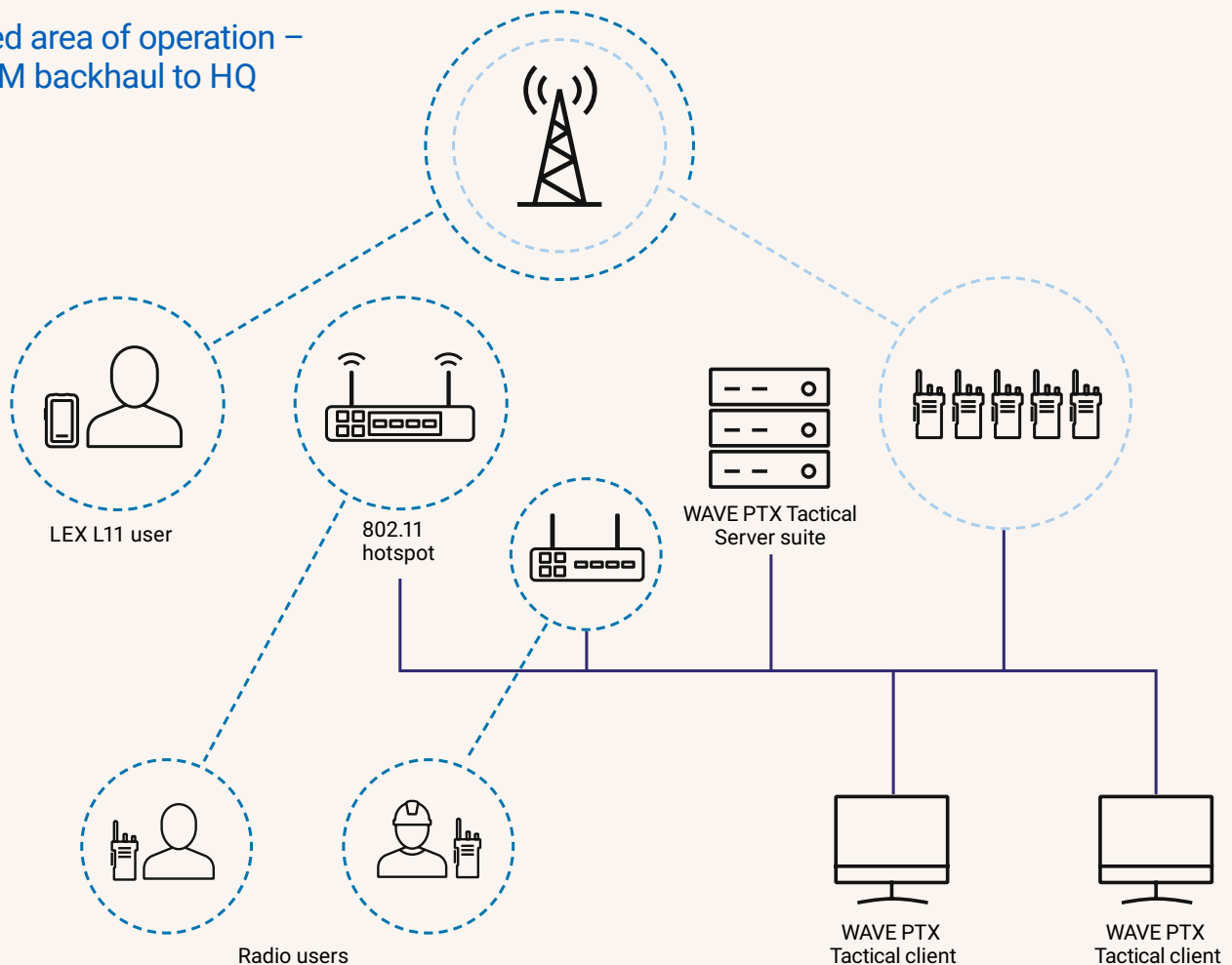

In an agile combat environment, it may be necessary to deploy multiple WAVE PTX Tactical systems to various geographically separated locations. A WAVE PTX Tactical domain within a deployed communications fly-away kit using inter-domain supernoding can federate WAVE PTX Tactical servers running at different fixed and deployed locations, while maintaining both local connectivity and reach-back connectivity to Mission and JTF headquarters, while maintaining both local connectivity and connectivity to TF and JTF headquarters.

Each deployed WAVE PTX Tactical system can choose to publish any or all of their connected radio channels to other systems running WAVE PTX Tactical over an IP-based connection, regardless of distance. Other authorized users can subscribe or publish resources across multiple WAVE

PTX Tactical systems and grant access to other responding agencies.

WAVE PTX Tactical servers from deployed locations can be temporarily trunked to WAVE PTX Tactical servers within an enterprise to provide true communications interoperability without prior coordination and configuration. WAVE PTX Tactical equips users with a single interface for complete unified communication that span unlimited distances and operational units.

These scenarios are similar to the current support WAVE PTX Tactical provides to USSOCOM for deployed interoperability between mobile and fixed assets for secure communications in expeditionary operations and in areas of low governance.

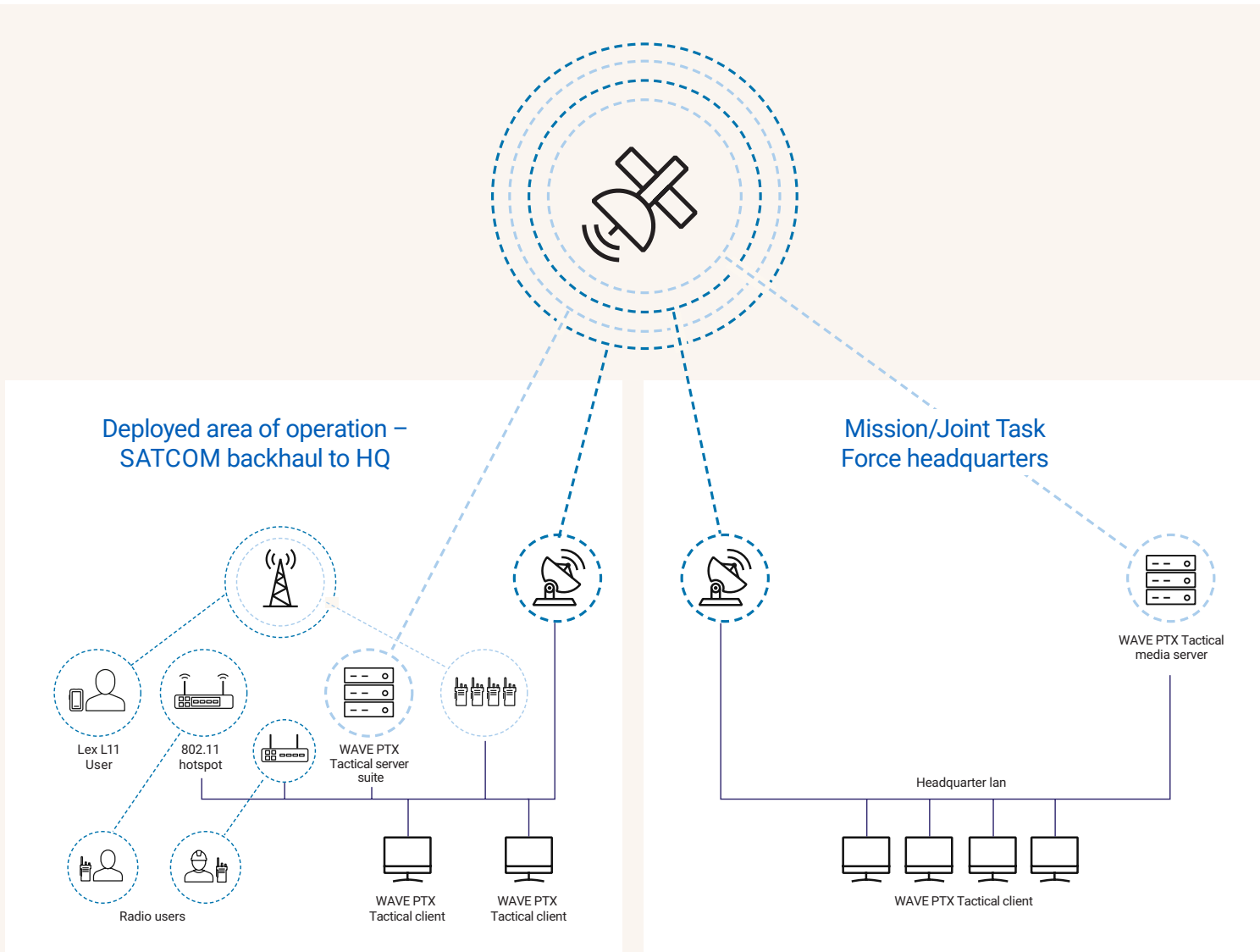

Fixed HQ - SATCOM backhaul to deployed ops

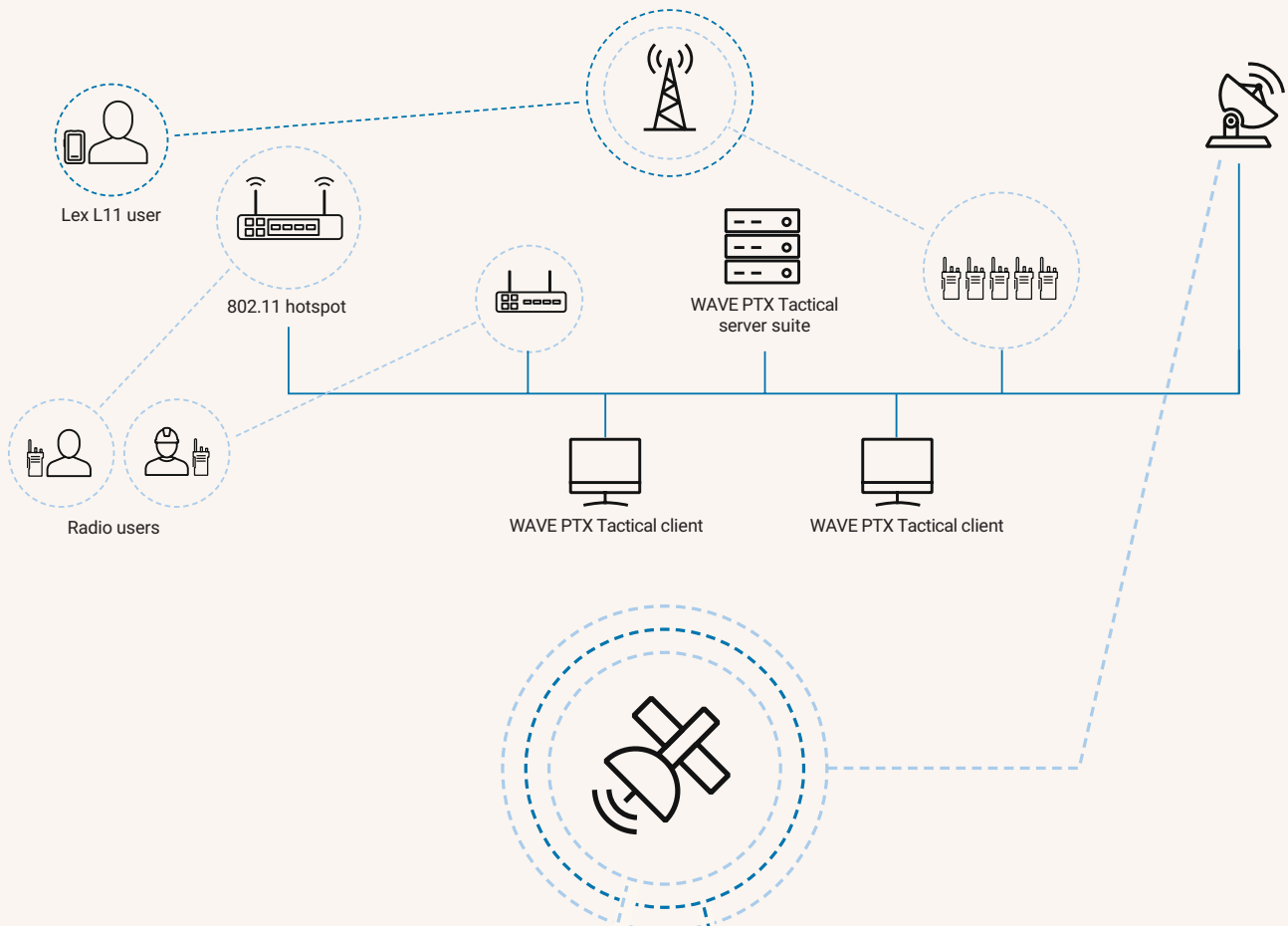

Deployed area of operation – SATCOM backhaul to HQ

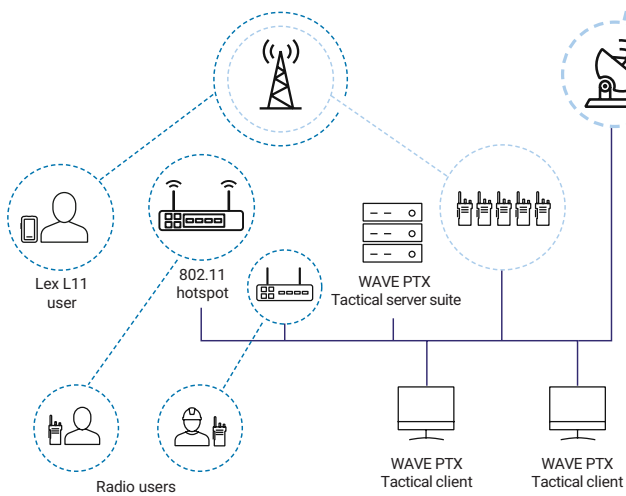

Mission/joint task force headquarters

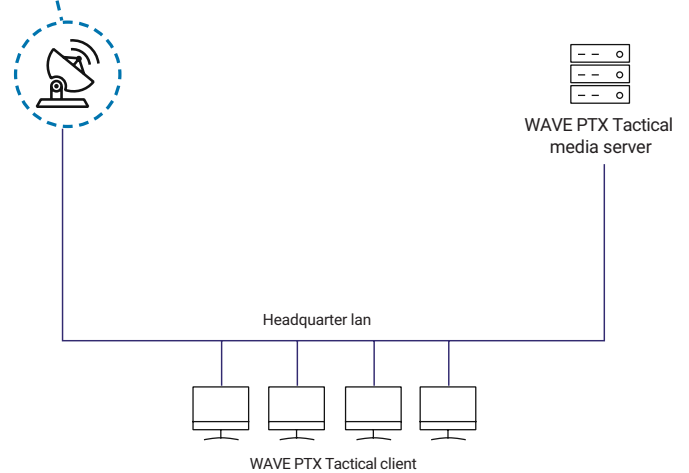

Fixed HQ - commercial ISP backhaul to deployed ops

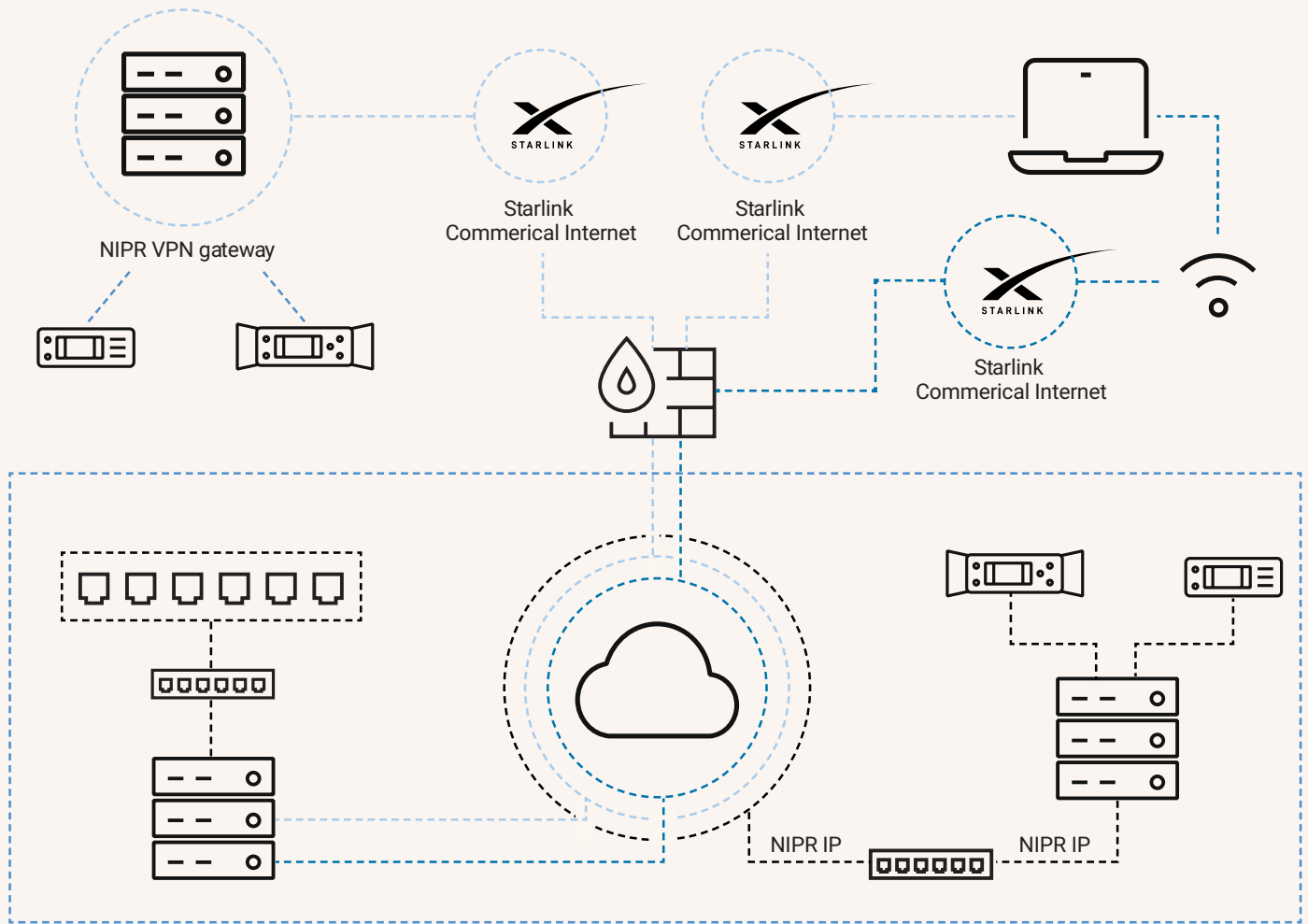

To learn more, visit:
www.motorolasolutions.com/waveptxtactical



Motorola Solutions, Inc. 500 West Monroe Street, Chicago, IL 60661 U.S.A. motorolasolutions.com

MOTOROLA, MOTO, MOTOROLA SOLUTIONS and the Stylized M Logo are trademarks or registered trademarks of Motorola Trademark Holdings, LLC and are used under license. All other trademarks are the property of their respective owners. ©2026 Motorola Solutions, Inc. All rights reserved. 03-2026 [MW02]