



# The Value of Reliable Audio in Mission Critical Radios:

Motorola APX™ P25 Multi-Band Portable Radios





Mission critical users, such as federal and public safety professionals, require portable radios that deliver exceptional audio clarity and loudness in environments where background noise is prevalent. In addition, first responder agencies are looking for communication technologies that empower their departments to perform their job duties safely and efficiently in a wide range of environments. Meeting the demanding needs of the mission critical user requires solutions that significantly enhance and optimize the full spectrum of audio quality—loudness, clarity, and intelligibility.

Motorola expands their portfolio of mission critical-designed solutions with its APX P25 multi-band portable radio. Developed using an innovative user-centric process from Motorola, APX provides first responders a solution that optimizes the vital aspects of portable radio audio quality while delivering exceptional performance in a variety of noise environments\*. Designed to be future ready, APX allows mission critical users to focus on protecting their personnel and the community, and not on their technology.

## Mission Critical Challenges Demand Portable Audio that's Loud and Clear

High stress, and high risk—both are cold realities encountered throughout the daily lives of mission critical users. In an emergency, all bets are off as the environment fills with crowd noise, sirens wailing, and activity on the scene. With all of this noise, how will responders be able to communicate on their portable radios? In mission critical situations, portable radio users cannot just step into a quieter environment or turn down the noise.

The fact is, high background noise and wind can severely impact audio transmit intelligibility and clarity. On the receive side, speech clarity and loudness can make the difference in high stress situations. Every word needs to come through loud and clear. Today's generation of mission critical users require ergonomic portable radios that provide maximum noise suppression on the transmit side, and louder and clearer audio on the receive side.

This position paper provides an overview of the audio features contained within APX portable radios, and shows how these features can deliver powerful benefits to users operating in environments where loudness, audio quality, and speech communications are critical.

\*Recent Studies have shown that communication systems can be affected by certain high noise sources such as alarm systems in self-contained breathing apparatus or chainsaws.



**APX portable radios feature a unique dual speaker and dual microphone design for optimized communication.**

## High Quality Audio Made Possible through the Power of Innovation

### When it comes to Public Safety Design, There are No Compromises

At Motorola, communications for mission critical users is serious business. With over 70 years of experience, our team of dedicated audio scientists and engineers leveraged the latest in digital signal processor (DSP) technology combined with state of the art electronics, acoustic microphones, and loudspeakers to deliver the APX P25 multi-band portable radio—a revolutionary solution for speech communications optimized for rigorous mission critical environments.

The unmatched Motorola experience in ergonomics, usability, and functionality served as the cornerstone for the APX design process. Created with the needs of mission critical users as requirement number one, APX delivers a no-compromises approach to portable audio communications, resulting in an effective, user-centric form factor. APX incorporates dual-sided ergonomics and functional grouping based upon importance and relatedness. The dual-sided design combines dual-speakers and dual-microphones with intelligent signal processing for superior noise suppression, speech clarity, and loudness—even in high noise and wind conditions.

### Transmit Audio – Dual-microphones and Intelligence Enables Superior Noise Suppression

With a single microphone input channel, traditional portable radios can only remove a relatively small amount of the background noise from the combined

speech plus background noise signal. If the noise level changes quickly, for example, when a squad car passes by, or when wind levels fluctuate, signal processing in other radios may not be able to compensate. Until now, signal-processing algorithms relied on static noise models computed between pauses in speech. As long as the noise is not too severe, and is relatively constant, a moderate amount of suppression is achievable. Often, however, background noise levels vary rapidly and over a wide range.

To improve transmit audio clarity, the APX audio architecture combines an adaptive, dual-microphone approach with advanced DSP technology. The APX radio contains two independent, highly sensitive microphone channels—one on the audio side, and one on the data side. Each channel drives an intelligent DSP that suppresses and compensates for most background noise, executes voice activity detection (VAD), and boosts the voice audio using automatic gain control (AGC), special filtering, and advanced real time noise suppression techniques. After signal processing conditions the speech and removes most of the noise, a P25 AMBE+2 vocoder encodes the digital audio stream for transmission. After carefully minimizing the background noise in the signal, the vocoder is able to process the remaining speech more effectively, resulting in a clear, enhanced speech transmission in most environments.

**APX™ P25 Multi-Band Portable Radio - Transmit**

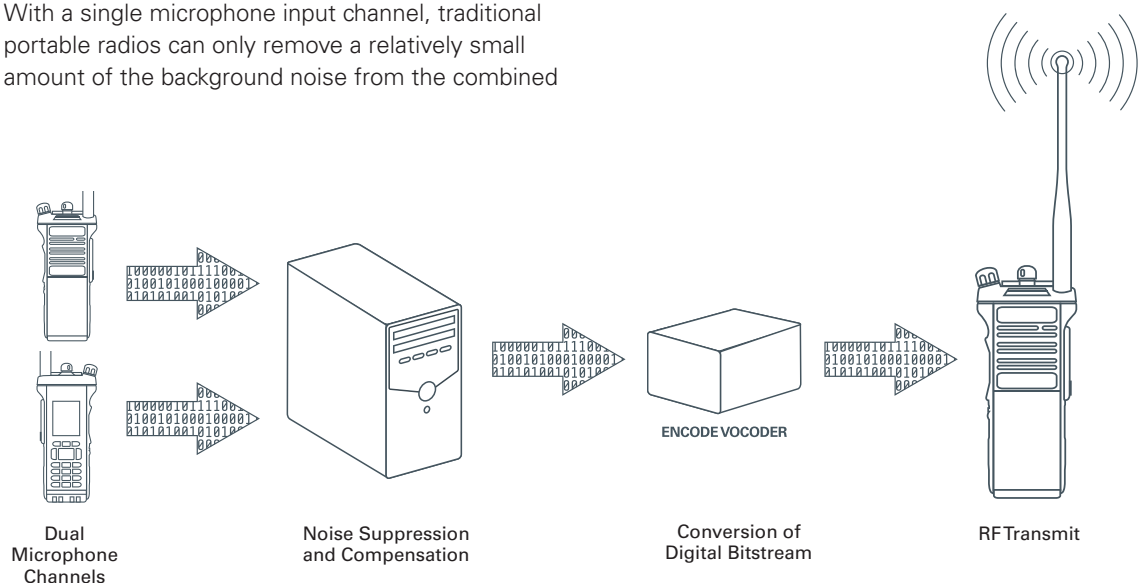

# The Dual Microphone Advantage

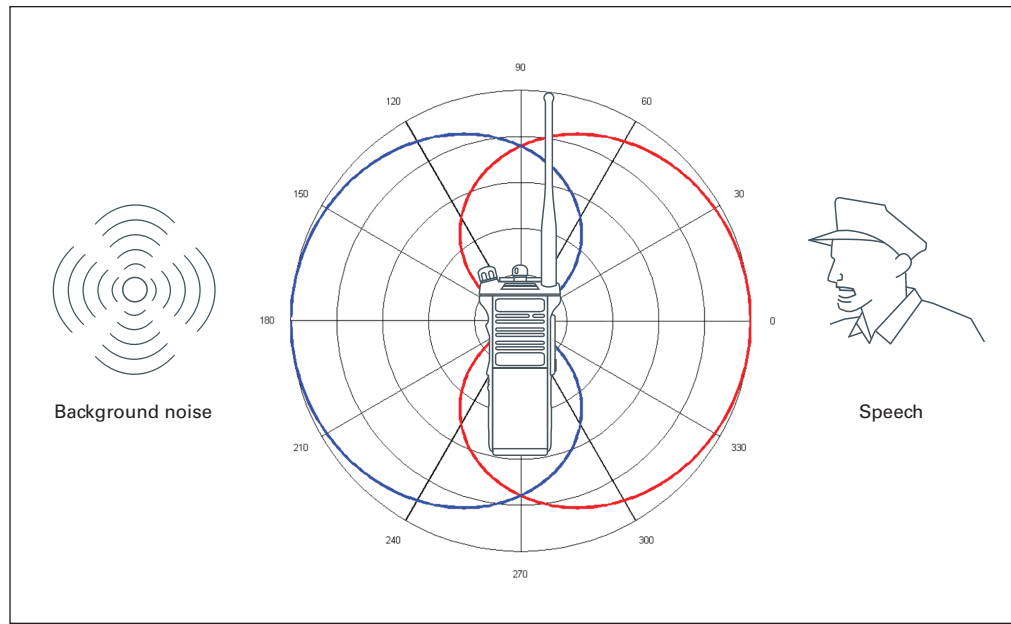

Dual Microphone Directional Sensitivity

The dual microphone/two-channel advantage comes into effect when a user engages the push to talk (PTT) button. With two audio sources as inputs, the DSP leverages the concept of directional selectivity, tracking the speech source while suppressing the interfering background noise outside of the audio beam. Dual microphones also allow the DSP to select the microphone with the best voice audio quality.

## Suppressing the Noise while Enhancing the Voice

The dual-microphone approach is highly effective in suppressing noise at the front end of the audio signal, but remains only one component of the APX audio system. APX aggressively removes noise from the audio source and distinguishes speech characteristics by using a high-speed, fast reacting signal processing scheme that runs up to ten times faster than typical phonetic speech events. The fast-acting noise suppression algorithm enables the APX to detect and compensate for rapid noise level changes, yielding a highly effective and efficient noise suppression solution.

## Optimized Results for Both Digital and Analog Modes

While on the job, mission critical users communicate using time-tested analog mode, or the newer, more secure digital modes. APX supports all three primary modes including 700/800 MHz analog/digital and VHF analog, P25 25 kHz and 12.5 kHz digital, and 6.25 kHz narrowband digital modes. Because APX significantly reduces noise in the voice audio mix, transmit speech processes through the vocoder louder and cleaner in most environments. The impact of APX noise suppression is even greater in digital modes and helps enable the processing of clear speech through the APX system.

# Superior Audio In Tough Environments



## Receive Audio – APX Maximizes Listening Clarity and Loudness

Mission critical teams function in a wide variety of environments ranging from high background noise to relative calm. Portable radios must provide superior quality in any environment. On the receive side, users face an added challenge when trying to differentiate voice sources, and distinguish multiple conversations while listening to multiple bands. Meeting these needs, APX contains two custom-designed loudspeakers—a large speaker on the audio side for high clarity and loudness, and a small speaker on the data side. With APX, users experience optimal sound quality from virtually any listening angle.

It takes more than just raw amplification power to ensure receive audio comes through loud and clear. After the APX receives the RF signal and decodes the signal into a digital stream, the DSP

takes over. At this stage, the DSP conditions the audio signal by introducing user-configurable gain control and splits the signal into two channels, one for each loudspeaker amplification path. To eliminate low frequency noise and conserve power, APX introduces high-pass filtering into the signal path. The DSP manages the volume for each speaker, balancing the sound pressure level generated by the two speakers, which optimizes the overall acoustic experience in most environments.

To maximize efficiency and control over audio gain and loudness, the APX uses a high-gain Class-D amplifier to drive the large speaker, and a traditional Class-AB amplifier to drive the small speaker. Class-D amplification provides the APX with the best possible balance between high output power and current draw rate, yielding ultra-high power efficiency.

### APX™ P25 Multi-band Portable Radio - Receive

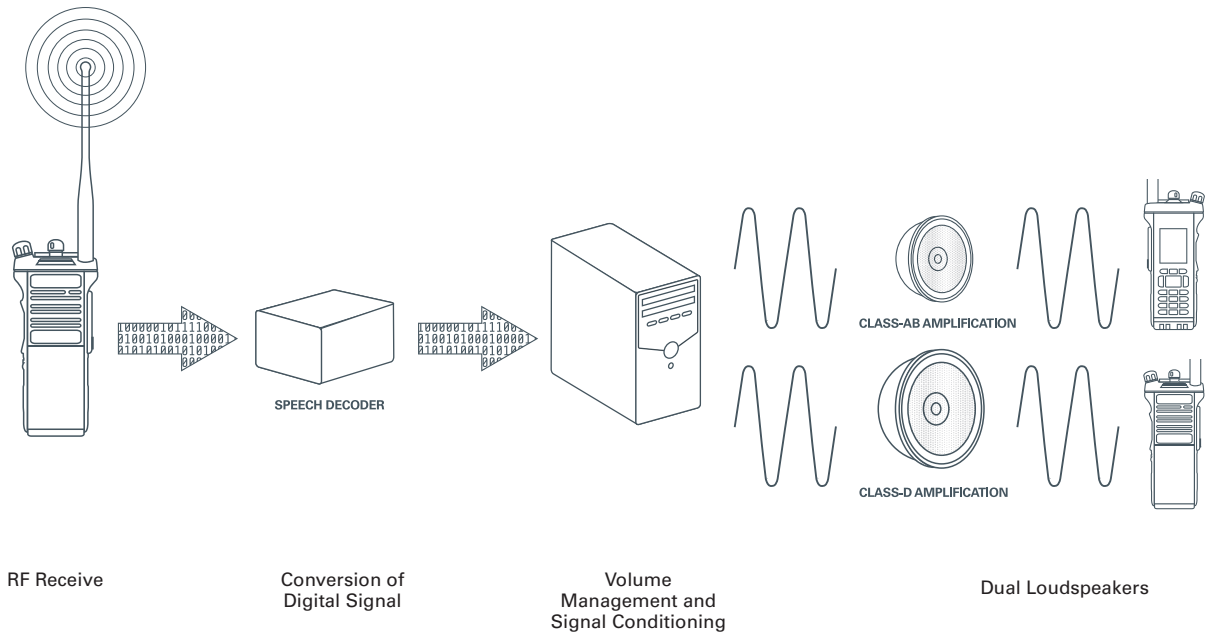

# Superior Audio In Tough Environments

## Distortion Management Boosts Audio Clarity

Distortion can degrade audio clarity, introducing buzzing that becomes noticeably audible in low noise conditions. To actively manage distortion, APX uses innovative signal processing algorithms that optimize very high amplitude peaks. Distortion management dramatically improves audio clarity, virtually eliminating the bothersome buzzing usually generated when a listener increases the audio volume. As the volume gets louder, APX increases the resistance to distortion, improving overall speech dynamics. In low noise environments, APX preserves receive voice audio quality, and delivers a level of natural sounding clarity. The result is clear, natural sounding speech for most environments.

radio closer to the ear improves the audio speech to noise ratio, making speech more understandable. However, what happens when the radio must remain on the belt or under your personal protective equipment?

Mission critical users need a communication solution that keeps their audio lifeline open—regardless of most high background noise levels. In high stress situations, public safety teams max out their radio's volume, which in other radios results in extremely distorted speech. APX audio volume is significantly louder, less distorted and able to cut through higher background noise levels than any portable public safety radio on the market in most environments.

## High Stress Situations Call for High Volume Audio

In high stress, high noise situations the first reaction is to bring the radio up close to the ear. This is usually quite effective since it dramatically increases the speech level without changing the noise. Moving the

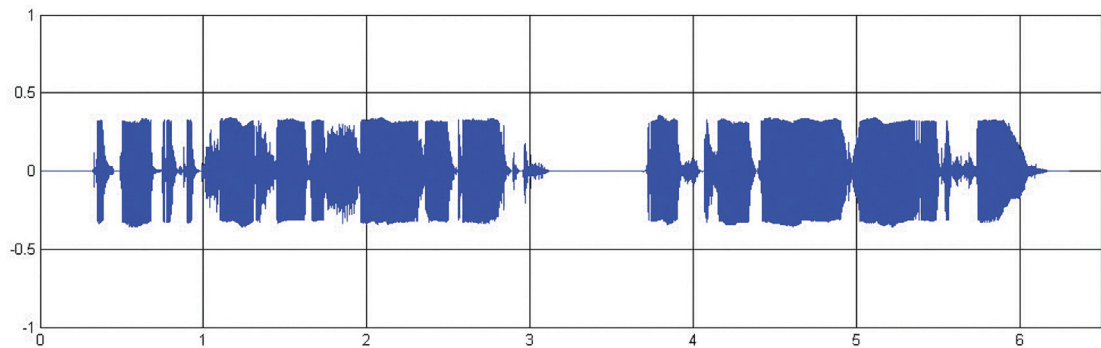

Distorted Speech Audio at Max Volume

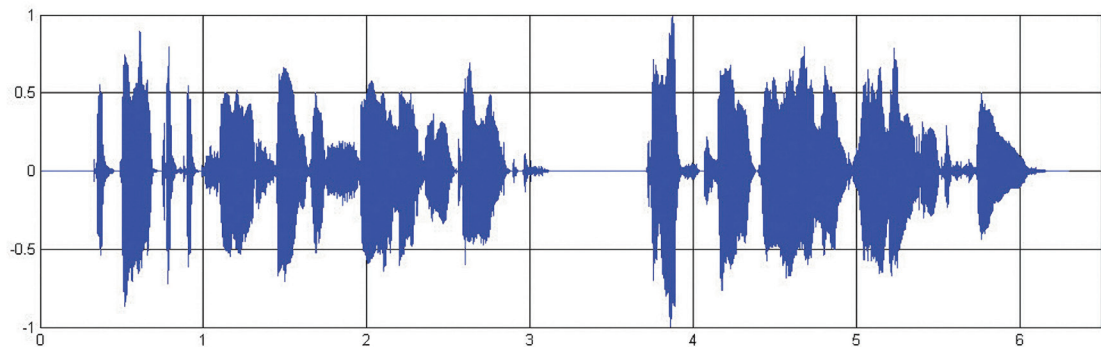

Distortion Management Applied – Speech Audio is Loud and Clear





## The APX Portable Radio – Achieving High Quality Audio for Mission Critical Challenges

Designed for the rigors of the mission critical environment, APX audio aggressively attacks background and wind noise, transmitting the clearest voice audio achievable in most environments. For the police officer on the beat, APX audio stands out when other portable radios wash out from city noise. Fire fighters can now feel more confident that they can hear their teammates, even in difficult fireground conditions. The result is a loud, clear, and understandable voice transmission that communicates to the dispatcher, another APX radio, or any other radio in the department with less in-channel acoustic noise than previously possible.

With the APX P25 multi-band portable radio, Motorola has once again revolutionized mission critical communications technology. Now, more than ever, first responders can rest assured that their portable radios stand ready to maintain their communication lifeline, freeing them up to focus on their mission of protecting their personnel and the community.

# **MOTOA<sup>4</sup>**

## *Mission Critical Portfolio*

### Technology That's Second Nature™

The APX™ P25 Multi-Band Radios are part of the MOTOA4 Mission Critical Portfolio of products that offer seamless connectivity between first responders. Motorola puts real-time information in the hands of public safety personnel to provide better information that enables better decisions for better outcomes. It's Technology That's Second Nature.

#### **APX P25 Multi-Band Radios**

Additional information and resources such as product information, brochures, and white papers are available on the APX product website found at [motorola.com/apx](http://motorola.com/apx).



## **MOTOROLA**

Motorola, Inc. 1301 E. Algonquin Road Schaumburg, Illinois, 60196, U.S.A. • 800-367-2346 • [motorola.com/apx](http://motorola.com/apx)

MOTOROLA and the Stylized M Logo are registered in the U.S. Patent and Trademark Office. All other product or service names are the property of their respective owners. All features, functionality and other product specifications are based upon the latest available information and are believed to be accurate; however such product specifications are subject to change without notice or obligation. © Motorola, Inc. 2008

RO-99-2166