

A 16 Digital Input 110V Module for the MOSCAD-L RTU

The 16 Digital Input module is an accessory to the MOSCAD-L RTU that allows up to 16 wet closures, from switches or relays in other on-site equipment, to be connected to the RTU. Examples include site or equipment door switches, centrifugal switches on motors, equipment malfunction switches, and tank float switches.

Data Input

Under the control of the defined Application Program, the CPU module will read the current instantaneous status of one or more of the 16 inputs. It will move that data from the 16DI module into the CPU module via the motherboard.

This data may then be used by the Application Program to perform the desired functions.

Low-Speed Counter Inputs

Each of the 16 digital inputs may be used as low-speed counter inputs if desired. The totalizing will be done within the CPU module under Application control.

Any number of counter inputs are easily obtained.

Wet Inputs

Each digital input accepts input currents from external sensors that provide a switched 120 Vac output.

A single module provides a common interface to most of the sensors likely to be encountered.

Time-Tagging

Any of the 16 digital inputs may be defined to tag the time of the input event with one millisecond accuracy.

This time may then be read and used in sequence-of-event actions, etc. or used later for historical reports.

Optical Isolation

All inputs are protected by optical isolators on the module.

Surge Withstand Capacity (SWC) conformance is assured for the safety of the equipment and technicians.

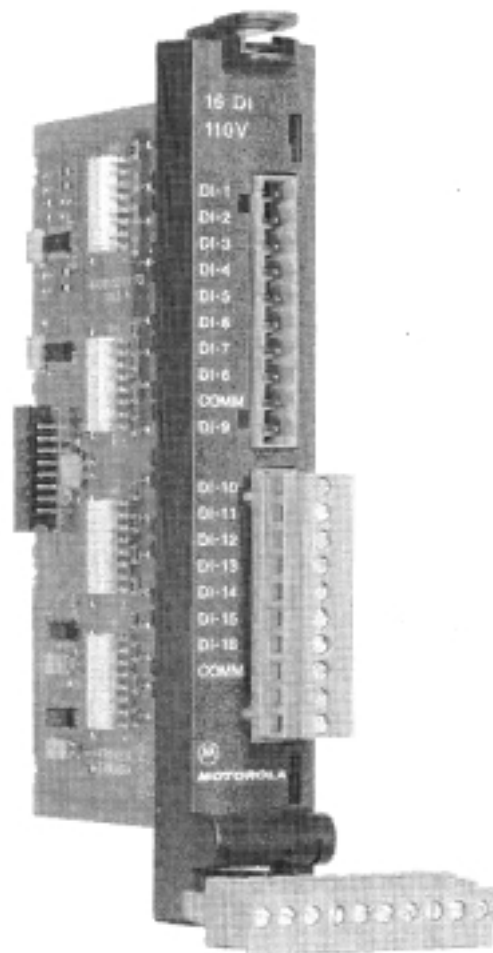

16DI 110V Module for the MOSCAD-L RTU

General Specifications

Inputs	Sixteen (16) inputs, 150 Vac maximum
Input Frequency	Without interrupt upon COS: 5 Hz maximum With interrupt upon COS: 50 Hz maximum
Input Signal	On: $V_{in} > 60\text{ V}$ or $I_{in} > 1.0\text{ ma}$ Off: $V_{in} < 30\text{ V}$ or $I_{in} < 0.3\text{ ma}$
Filtering	Software control of hardware filtering: 2-38 msec. Longer filtering within the application.
Interrupt upon COS	Event time-tag resolution = 5 msec.
Isolation	Per IEC 255-5: between ser connection and logic = 2.5 kV; insulation resistance = 100 Mohm @ 500 V; insulation impulse = 5 kV
Protection	Per ANSI/IEEE C37.90.1-1989: oscillatory wave = 2.5 kV; fast transient = 4 kV Per IEC 801-2: air discharge = 8 kV contact; 4 kV contact Per IEC 801-3: radiation immunity = 10 V/m Per IEC 801-4: fast transient = 500 V
Diagnostics	LEDs on CPU module: 16 input status

Equivalent Input Circuit

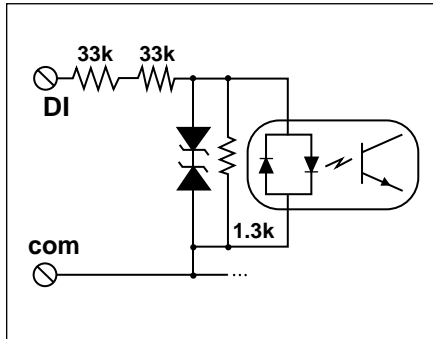

Sensor Wiring

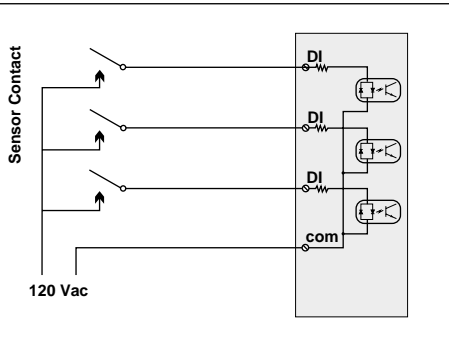

Connections Chart

Term	Function	Term	Function	Term	Function	Term	Function
1	In-1	6	In-6	11	In-10	16	In-15
2	In-2	7	In-7	12	In-11	17	In-16
3	In-3	8	In-8	13	In-12	18	com 9-16
4	In-4	9	com 1-8	14	In-13	19	Not used
5	In-5	10	In-9	15	In-14	20	Not used

MOTOROLA

Motorola U.S.A.
1301 E. Algonquin Road
Schaumburg, Illinois 60196
Phone: 1-888-567-7347

Motorola Canada Ltd.
3900 Victoria Park Avenue
North York, Ontario M2H 3H7
Phone: 1-800-268-5758

Motorola Latin America Division
8000 W. Sunrise Blvd.
Plantation, FL 33322
Phone: 1-954-723-8563



Motorola Asia Pacific Ltd.
39/FL NatWest Tower
Times Square, Causeway Bay
Hong Kong, PRC-SAR
Phone: 852-2966-4366

Motorola UK Ltd.
Jays Close, Viable Industrial Estate
Basingstoke, Hampshire
RG22 4PD
Phone: +44-1256-484341

©, Motorola, and MOSCAD are trademarks of Motorola Inc.

All company and product names are trademarks or registered trademarks of their respective companies

Printed in U.S.A. (0105) VPS

Motorola is an Equal Employment Opportunity/Affirmative Action Employer

Visit us on the Web at <http://www.mot.com/MOSCAD>